



Environmental Engineering



Technical and Environmental Equipment

**Kerkhofstraat 33
2220 Heist-op-den-Berg
Belgium
Phone +32/(0)15 24 21 15
Fax +32/(0)15 24 55 16
info@task.be
www.task.be**



Environmental Engineering

Technical equipment for industrial emission and waste water treatment plants

Selection

TASK Environmental Technology – division Technical and Environmental Equipment - is also supplier of all technical equipment for the construction of new and the renovation of existing industrial gas treatment plants, odour control and waste water treatment plants. Years of experience and know-how in the field of industrial waste water, gas treatment and odour control and a thorough knowledge of the market allow us to select the most appropriate equipment for the construction of new or renovation of existing environmental sanitation facilities. We also can offer the most adequate solution in the field of water recycling systems.

Experience

Throughout the years Task Environmental Engineering has been able to gain extensive experience in the field of waste water treatment and odour control and has gathered a comprehensive list of successful references; as a result we assist our customers in word and deed in order to select the most appropriate equipment for each treatment plant. Each plant has its own specific requirements; selecting the most appropriate equipment is of crucial importance for an optimal performance of your environmental investments. We import high technological and quality equipment from Europe as well as from the rest of the world, our aim is to select for each customer the most adequate and the most economic equipment for each specific application.

Integrated solutions

We always start from the specific needs of your company, aiming to bring those into line with a selection of the best price-quality equipment, taking into account not only the present situation, but also including the estimated production capacity forecast of your plant. Quality, service and reliability remain the keywords to our success.

Selecting the right equipment is of crucial importance for a smooth functioning and optimal performance of your environmental investments. Task disposes of the know-how and the experience to advise you, taking into account your specific demands and the production circumstances in your company.

AGITATORS

- coagulation agitators
- flocculation agitators
- neutralization agitators
- floating mixers

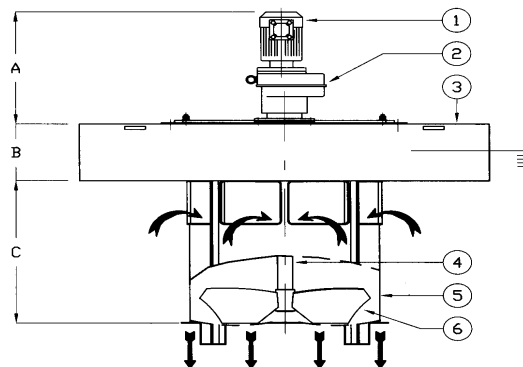

www.task.be

More than 20 years of experience !

AERATION

- fixed low speed surface aerators
- flotating low speed surface aerators
- jet aeration



GAS SCRUBBERS (COMPACT TO LARGE VOLUME)

- gas scrubbers for storage tanks
- small scale gas scrubbers for laboratories



SPECIAL UNITS

- pilot plants (emission, odour, water)
- dosing skids
- sludge treatment installations
- oil separators (various types)
- lamellar decantors, sludge thickeners,...
- polymer production units / preparation of powdered or liquid flocculants
- neutralisation units



INTERNALS FOR GAS SCRUBBERS

- packing (structured packing & bulk tower filling)
- droplet separators
- demisters

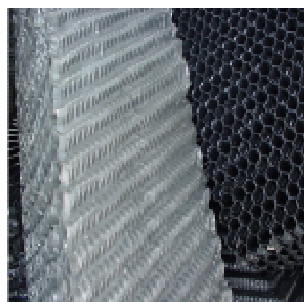

TASK

Environmental Engineering

Technical equipment for industrial emission and
waste water treatment plants, odour control

www.task.be

- *agitators*
- *polymer production units /
preparation of powdered or liquid
flocculants*
- *neutralization units*
- *aeration – jet aeration*
- *special units*
- *gas scrubbers*
- *internals for gas scrubbers (packing,
droplet separators, demisters)*
- *oil separators*
- *dosing skids*
- *sludge treatment*



Technical and Environmental Equipment

TASK Environmental Engineering bvba - Kerkhofstraat 33 - 2220 Heist-op-den-Berg
Phone +32/(0)15 24 21 15 - Fax +32/(0)15 24 55 16 - info@task.be - www.task.be - BE 0461.006.851